

MODEL: AX-DD 630/4

Motor Speed 1400 RPM
 Motor enclosure TEFC
 Number of blades 12
 Blades Material GRP
 Casing Galvanised mild steel
 Power supply 415V 3 phase 50Hz

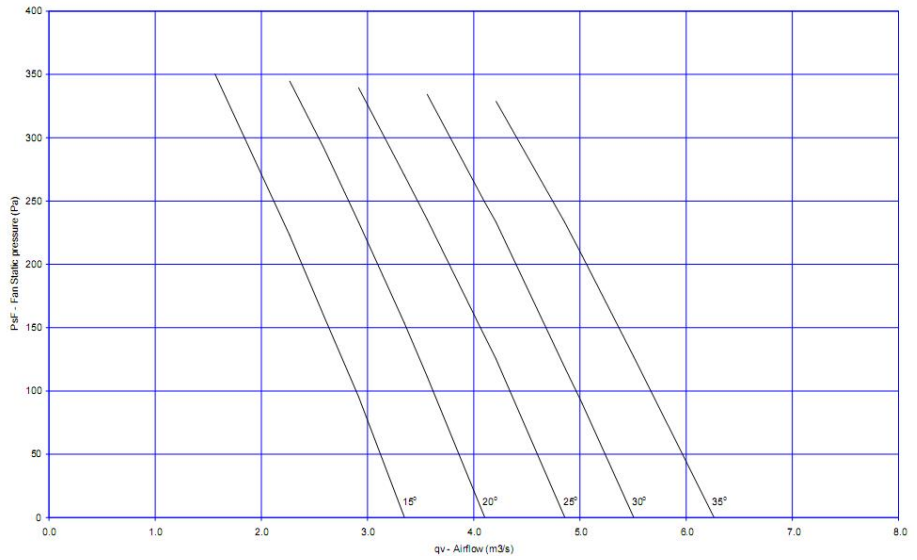

* Externally mounted weather proof plastic terminal box
 * Performance standard BS 848

Blade Pitch Angle (°)	15	20	25	30	35
Motor Power (kW)	1.10	1.50	2.20*	2.20*	3.0*

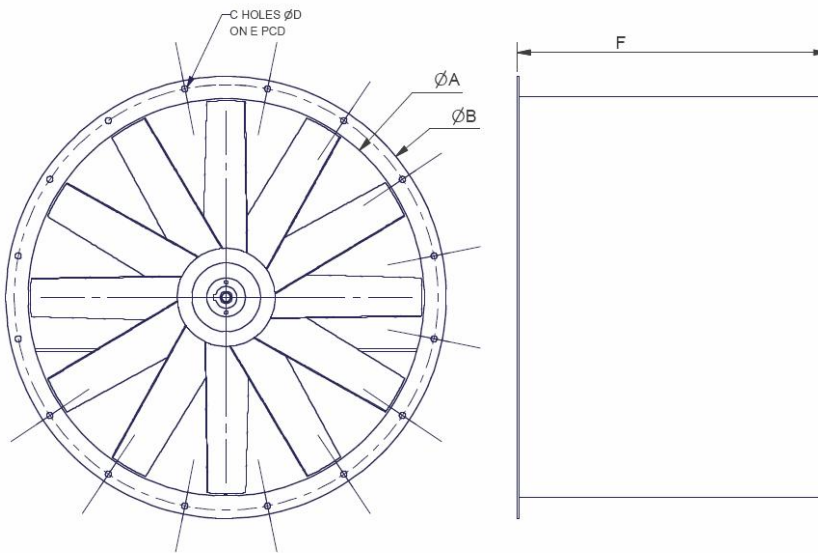

A	B	C	D	E	F	* F
630 mm	715 mm	12	12 mm	690 mm	400 mm	* 600 mm



Industrial and Commercial Fan Store

Fanpro Pty. Ltd.
 7/97 Bayfield Road East
 Bayswater
 Victoria 3153
 Australia

Phone: 61 3 9018 7137
 Fax: 61 3 9720 7133
 E-mail: salesdept@fanpro.com.au